

Our Ref : LTA/AMG/1AM/C60.039.001

LTA/DBC/R70.018.001

Date : 11 Jan 2023

Who should know

Building Owners, Developers, Architects, Engineers, Transport/Traffic Consultants and Builders

Dear Sir/Madam

PUBLICATION OF ACTIVE MOBILITY DESIGN GUIDE AND CHECKLIST FOR DEVELOPMENT SUBMISSIONS

1. In collaboration with the Singapore Institute of Architects (SIA) and Association of Consulting Engineers Singapore (ACES), the Land Transport Authority (LTA) has developed a design guide and checklist to assist industry professionals in preparing development submissions involving activity mobility aspects. The design guide outlines the design considerations and guidelines for Active Mobility related elements to promote a conducive and safe environment for walking and cycling. Qualified Persons (QPs) are strongly encouraged to take these design guidelines into consideration when preparing and making submissions to LTA.
2. To further streamline development submissions and their review, LTA has identified a list of Active Mobility related items to be designed by the QPs prior to the submission to LTA. With effect from 1 Feb 2023, QPs will be required to complete and submit the Active Mobility Checklist, and check that all relevant Active Mobility related items have been incorporated into the first Layout Plan (Development Control Plan) submission to LTA. The checklist will be required to be submitted for all development proposals, except for the following:
 - a. Addition & Alteration (A&A) proposals that do not involve proposed works within the public street
 - b. All landed residential developments
 - c. Individual shophouse developments along a street block

3. Please scan the QR code below or visit https://www.lta.gov.sg/content/ltagov/en/industry_innovations/industry_matters/development_construction_resources.html to access the design guide and checklist under the Active Mobility tab.



Dissemination & Feedback

4. We would greatly appreciate your assistance in disseminating this circular to members of your organisation and to others who may find this information useful. We can be reached at LTA_AMU_Registry@lta.gov.sg if there is any feedback or suggestion for the design guide and checklist.

Chan Boon Fui
Group Director
Active Mobility Group

Chan Chin Kai
Director
Development & Building Control

ACTIVE MOBILITY

DESIGN GUIDE

For Development Submissions

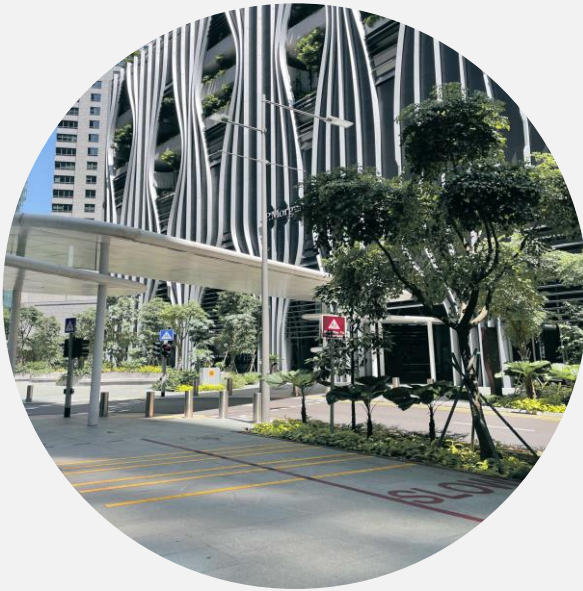

This guide outlines the design considerations and guidelines for Active Mobility related elements to promote a conducive and safe environment for walking and cycling. Qualified Persons preparing a development submission are advised to take these guidelines into consideration to facilitate review and clearance.

The guidelines and examples found in this guidebook are not exhaustive in covering all possible site conditions. In evaluating a development submission, LTA may provide further guidance based on the proposed design depending on merits.

Where mentioned in this guidebook, Active Mobility Device Users refer to Bicycles, Power-Assisted Bicycles (PABs), Motorised and Non-motorised Personal Mobility Devices (PMDs) and Personal Mobility Aids (PMAs). PABs and Motorised PMDs are not allowed on footpaths.

CONTENTS

1.0	WALKING & CYCLING INFRASTRUCTURE	3
	1.1 Information to be Incorporated into DC Plans	
	1.2 Information to be Incorporated into Street Plans	
	1.3 Gazette Requirements for Cycling Paths	
2.0	VEHICULAR ACCESS	8
	2.1 Information to be Incorporated into DC Plans	
	2.2 Qualities of a Good Design	
	2.3 Examples of Traffic Calming Measures	
3.0	PEDESTRIAN ACCESS	12
	3.1 Information to be Incorporated into DC Plans	
4.0	BICYCLE PARKING	14
	4.1 Information to be Incorporated into DC Plans	
	4.2 Geo-fencing Requirements for Bicycle Parking	
5.0	END-OF-TRIP FACILITIES	16
	5.1 Information to be Incorporated into DC Plans	
6.0	INTERNAL CIRCULATION	17
	6.1 Information to be Incorporated into DC Plans	
7.0	WAYFINDING SIGNAGE	18
	7.1 Information to be Incorporated into DC/BP Plans	
8.0	REFERENCES	19

1.0 WALKING & CYCLING INFRASTRUCTURE

PLANNED CYCLING PATH

The consultant shall first check if there is planned cycling path abutting the development. The information can be obtained from URA SPACE following the steps below:

1. Visit <https://www.ura.gov.sg/maps>
2. Check Control Plans
3. Click "Filters"
4. Activate the "Connectivity" layer

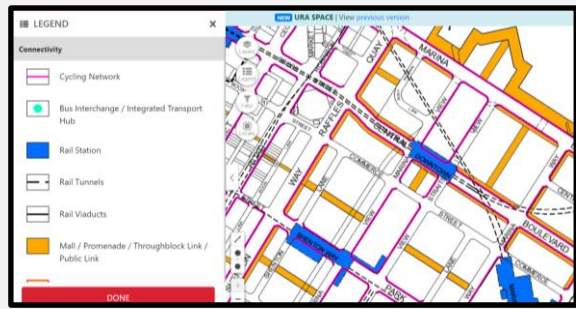

Figure 1.1 - Cycling Path Network in URA Space

If there is a planned cycling path abutting the development, LTA may advise the developer to improve the existing side table by widening the path and implementing 2m dedicated cycling path in addition to the 1.5m footpath, including any associated cycling path marking, signage, lighting along the cycling path, as well as widen existing crossings to enhance connectivity of the cycling path network. Details of the cycling path and crossings can be found in the prevailing Standard Details of Road Elements (SDRE) - Chapter 21.

Should the surrounding cycling path network not be ready when the development is completed, LTA may advise the developer to provide a widened footpath with embedded conduits for the provision of future cycling path lighting, according to the prevailing SDRE. LTA will complete the cycling path network in due course.

For developments that have submitted a Walking and Cycling Plan (WCP) at TIA pre-scoping stage, please ensure that provisions in DC plans and WCP are consistent.

1.1 Information to be Incorporated into DC Plans

- 1) The width of footpath / cycling path / covered linkway / crossings shall be indicated clearly on plan and cross section details. If there are any columns/footings along the path, the clear width of the path shall also be shown accordingly.
- 2) Please ensure that there is 0.6m lateral clearance between the outer edge of the road kerb and any element (footpath / cycling path / covered linkway).

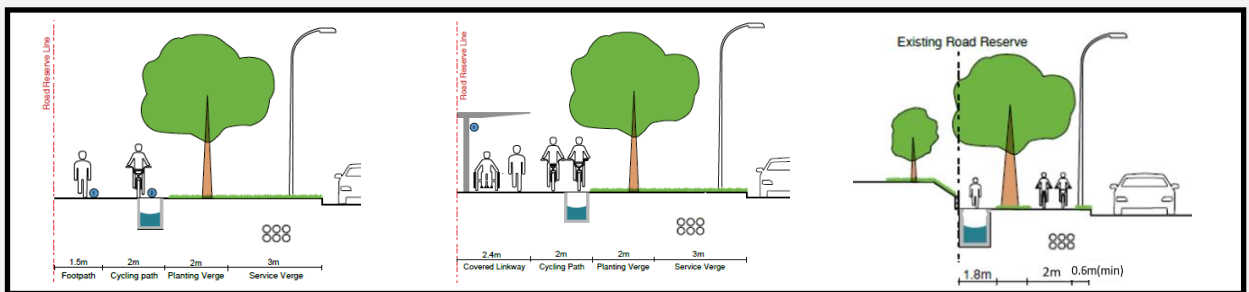

Figure 1.2 - Roadside Typologies

- 3) All paths shall be free from encumbrances (i.e. linkway columns, OG Boxes, Lamp Poles) to prevent any reduction to the effective clear width of the path.

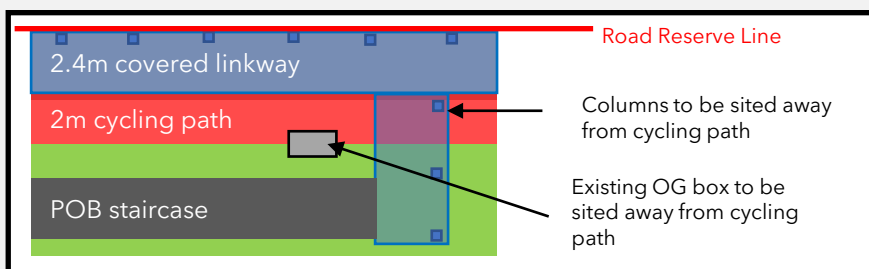

Figure 1.3 - Paths shall be free from encumbrances

1.0 WALKING & CYCLING INFRASTRUCTURE

1.1 Information to be Incorporated into DC Plans

4) Crossings at vehicular accesses shall follow the same width of path upstream/downstream, and shall be provided at flat level for the safety of path users. Gradient of entrance approach shall not encroach on the crossing.

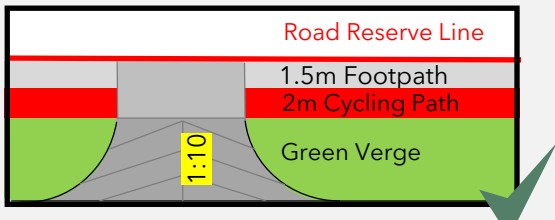

Figure 1.4 - Example of Vehicular Access where Gradient of Entrance Approach Stops at the Edge of the Crossing (Accurate)

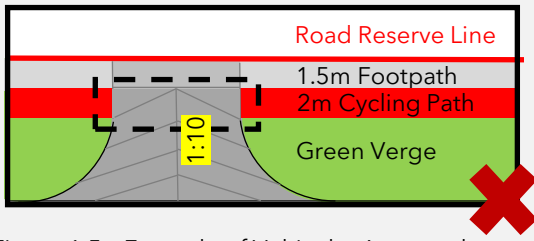

Figure 1.5 - Example of Vehicular Access where Gradient of Entrance Approach Encroaches the Crossing (Inaccurate)

5) Provision of minimum 1.2m high railings are recommended along cycling path with lateral clearance of less than 1.5m, and

- Level difference of 1m or more, and
- Slope equal or steeper than 1:3

The railings shall not reduce the clear width of cycling path.

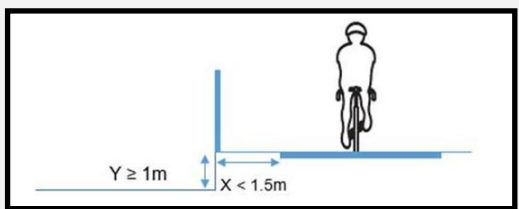

Figure 1.6 - Level Difference of 1m or more

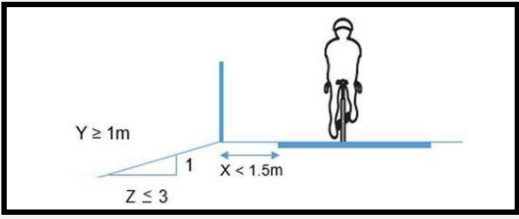

Figure 1.7 - Slope equal or steeper than 1:3

6) To avoid sharp turns along the path (eg. 90 degree kinks), please illustrate and ensure smooth tapering between 2m cycling path and 1.5m footpath to 1.5m footpath/2.5m shared path based on the minimum turning radius indicated in the diagram below.

Please illustrate and indicate any encumbrances within the path that will affect the line of sight. Please ensure that the minimum stopping sight distance for active mobility users (12m for footpath, 23m for cycling/shared path) can be met.

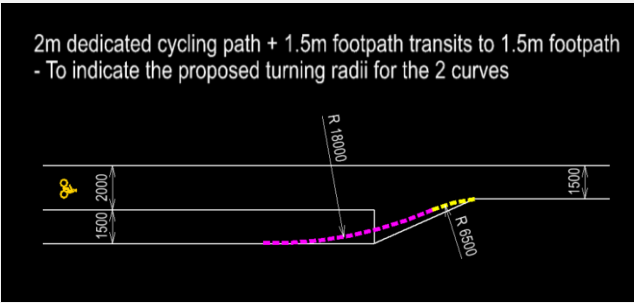

Figure 1.8 - Tapering of 2m Cycling Path and 1.5m Footpath to 1.5m Footpath

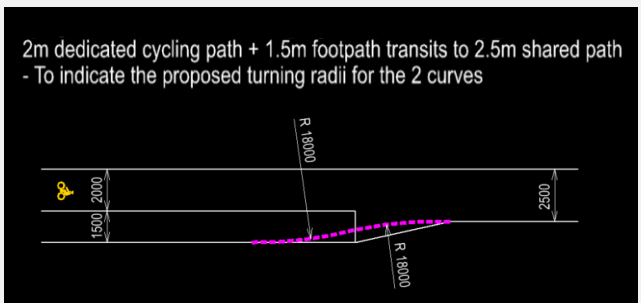

Figure 1.9 - Tapering of 2m Cycling Path and 1.5m Footpath to 2.5m Shared Path

1.0 WALKING & CYCLING INFRASTRUCTURE

1.1 Information to be Incorporated into DC Plans

6) For other scenarios, please illustrate and ensure smooth tapering based on the minimum turning radius and stopping sight distance indicated in the table below.

Type of Path	Design Speed (km/h)	Minimum Radius (m)	Stopping Sight Distance
Footpath	15	6.5	12
Cycling/ Shared Path	25	18	23

Table 1.1 - Minimum Turning Radius and Stopping Sight Distance

7) It is important to ensure that line of sight at corners is not hindered by hard structures and tall/dense vegetation to minimise any possible head on collisions.

Splayed/porous design at corners would enhance safety as it allows pedestrians and active mobility device users to see one another clearly and ensure that there is sufficient time to take any necessary evasive actions to avoid collisions. The submission of 3D artist impressions would help to better illustrate the design and facilitate clearance.

DESIGN CONSIDERATIONS

- Splayed/porous design at corners
- Avoid hard structures and tall/dense vegetation (more than 0.5m) within the visibility splay area
- To illustrate that minimum 12m/23m stopping sight distance can be achieved along the footpath/cycling path
- If hard structures cannot be relocated, path can be realigned further away round the bend to improve sight distance
- Traffic calming measures are also recommended to slow down path users

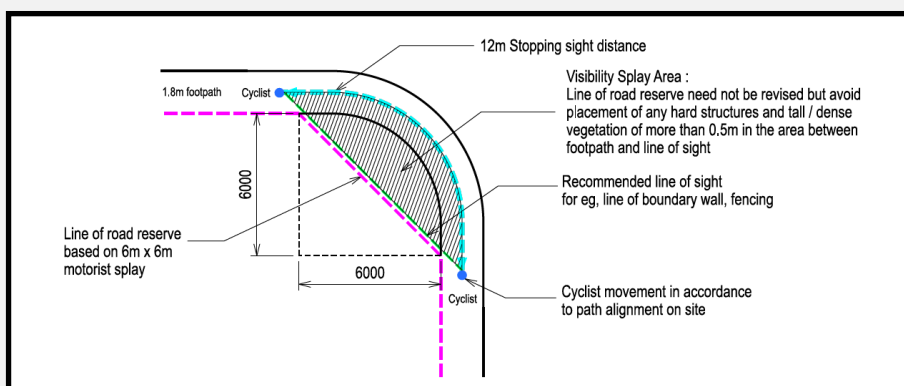

Figure 1.10 - Designing for Clear Line of Sight at Corners (Footpath)

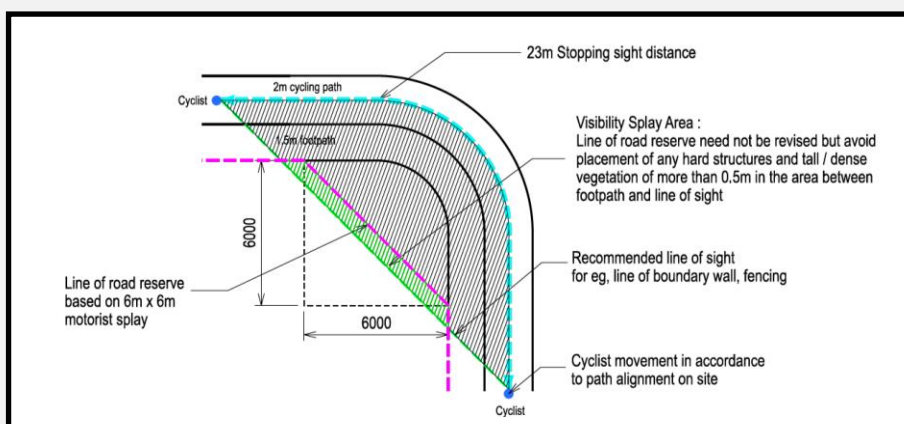

Figure 1.11 - Designing for Clear Line of Sight at Corners (Cycling Path)

1.0 WALKING & CYCLING INFRASTRUCTURE

1.1 Information to be Incorporated into DC Plans

DESIGN WITH CLEAR LINE OF SIGHT



Figure 1.12 - Corner with Splayed Design and Low Vegetation



Figure 1.13 - Corner with Porous Boundary and Low Vegetation

DESIGN WITH OBSTRUCTED LINE OF SIGHT (TO AVOID)



Figure 1.14 - Corner with Non Porous Wall and Tall/dense Vegetation



Figure 1.15 - Corner with Obstructed Line of Sight due to Reflective Glass

1.2 Information to be Incorporated into Street Plans

- 1) Cycling related markings and signages shall be provided in accordance with the prevailing SDRE and clearly shown on plan.
- 2) The connection between existing footpath and new cycling path/widened footpath should have dowel bars to prevent any differential settlement at the joint.
- 3) Gratings provided shall be concrete in-filled gratings in accordance with the prevailing SDRE.
- 4) Cycling path lighting shall be provided in accordance with the prevailing SDRE. The desired lighting levels for cycling paths are as follows:

Area	Minimum Average Illuminance (At Floor Level)	Minimum Lux (At Floor Level)	Uniformity
Non-Conflict areas	5 lux	2 lux	0.25
Conflict areas	10 lux	3 lux	0.25
Adjacent to Covered linkway	The covered linkway lights shall be designed to illuminate both the linkway and cycling path in accordance to the Walking and Cycling Design Guide Chapter 2		

Table 1.2 - Lighting Requirements

2.0 VEHICULAR ACCESS

Due to the high speed differential between motorists and pedestrians/active mobility device users, it is important to ensure that sight line at vehicular accesses is not hindered by hard structures and tall/dense vegetation to minimise any potential collisions. Splayed/porous design would allow motorists exiting the development to clearly see incoming pedestrians/active mobility device users commuting along the path and vice versa, ensuring that there is sufficient time to take any necessary evasive actions to avoid collisions.

DESIGN CONSIDERATIONS

- Splayed/porous design (eg. visually permeable fencing) for boundary wall near vehicular access
- Avoid hard structures and tall/dense vegetation (more than 0.5m) within the line of sight triangle
- Guardhouse, if located in between ingress and egress, shall not impede sight visibility
- Illustrate that minimum 12m stopping sight distance along the path can be achieved
- For any pedestrians and active mobility device users conflict area(s) with vehicular traffic, conflict mitigating measures shall be provided to enhance safety of pedestrians/active mobility device users

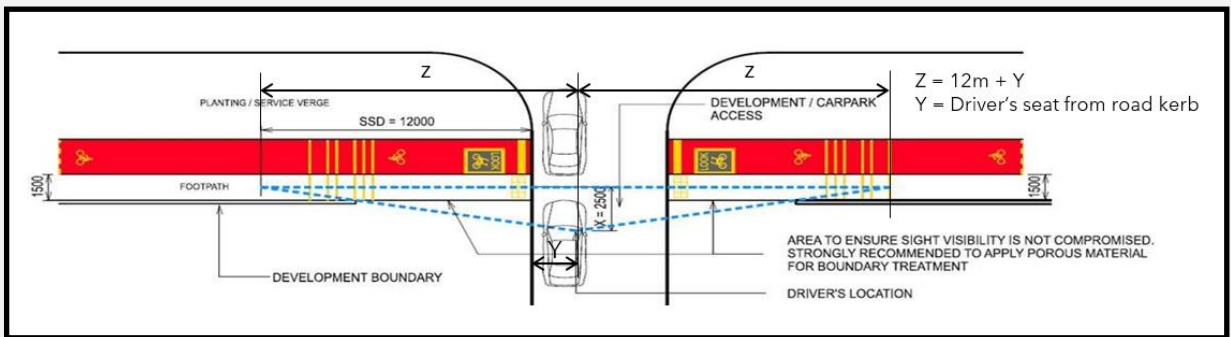

Figure 2.1 - Designing for Clear Line of Sight at Vehicular Access

DESIGN WITH CLEAR LINE OF SIGHT



Figure 2.2 - Vehicular Access with Porous Boundary

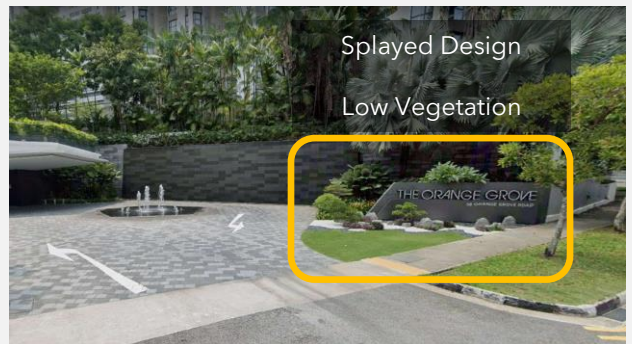

Figure 2.3 - Vehicular Access with Splayed Design and Low Vegetation

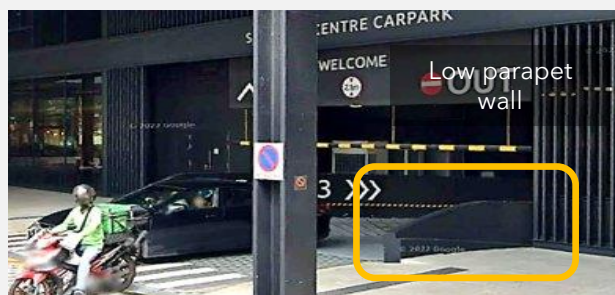

Figure 2.4 - Vehicular Access with Low Parapet Wall

2.0 VEHICULAR ACCESS

DESIGN WITH OBSTRUCTED LINE OF SIGHT (TO AVOID)

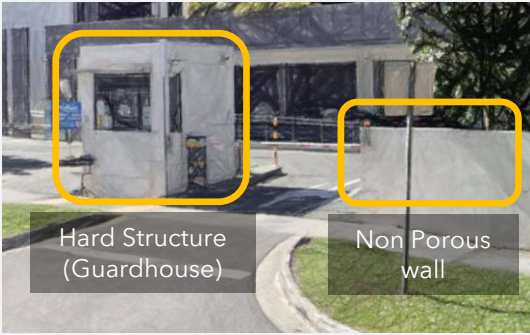

Figure 2.5 - Vehicular Access with Hard Structure and Non Porous Wall



Figure 2.6 - Vehicular Access with Hard Structure

2.1 Information to be Incorporated into DC Plans

- 1) The layout plan and elevation view shall be submitted for LTA's evaluation.
- 2) The submission of 3D artist impressions would help to better illustrate the design and facilitate clearance.

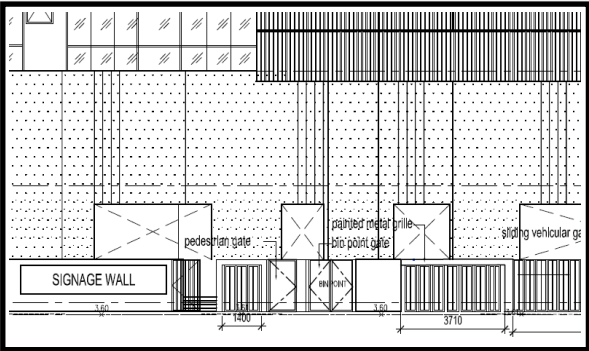

Figure 2.7 - Example of Elevation View

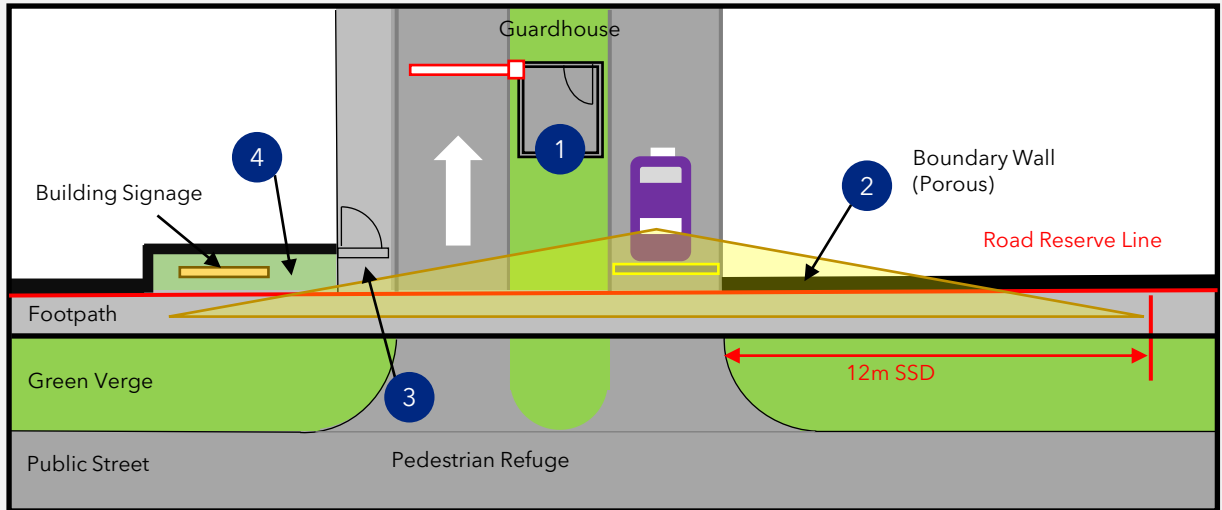

Figure 2.8 - Example of 3D Artist Impression

2.0 VEHICULAR ACCESS

2.2 Qualities of a Good Design

DEVELOPMENT WITH BOUNDARY WALL



- 1 Guardhouse shall be positioned away from vehicular access and not obstruct line of sight
- 2 Boundary wall with porous design
- 3 Pedestrian refuge with a safe holding area for development users
- 4 Any hard structures and/or vegetation within the line of sight triangle shall not be higher than 0.5m

DEVELOPMENT WITH COVERED WALKWAY AND NO BOUNDARY WALL

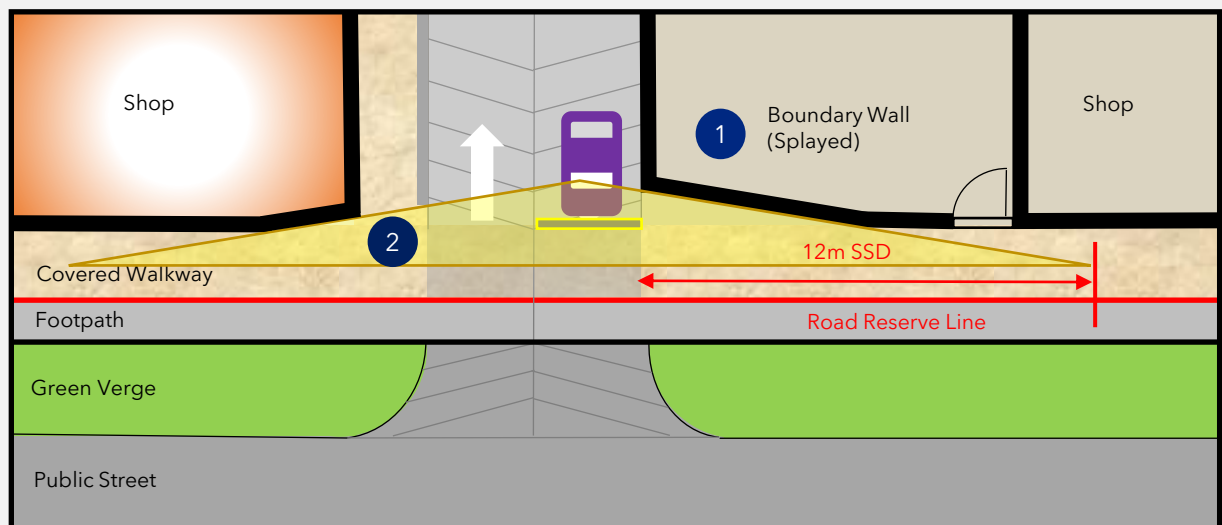

- 1 Boundary wall with splayed design
- 2 Any hard structures and/or vegetation within the line of sight triangle shall not be higher than 0.5m

2.0 VEHICULAR ACCESS

2.3 Examples of Traffic Calming Measures

Besides **1** the standard provision of signs and markings in accordance with SDRE, QP can also consider the following traffic calming measures.

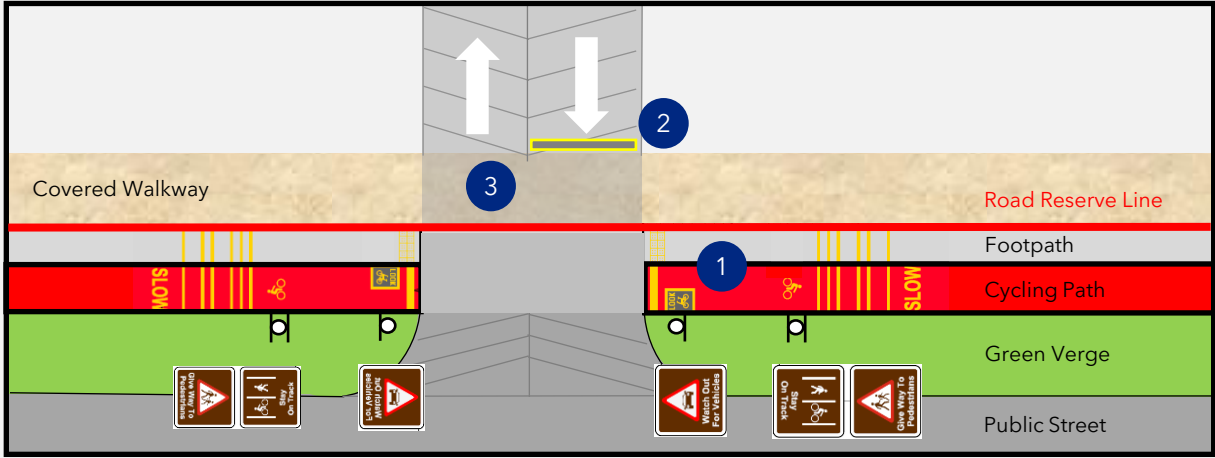

- 2** Provision of hump at egress.
- 3** Usage of varying materials at the conflict point to heighten motorists' awareness of pedestrians.

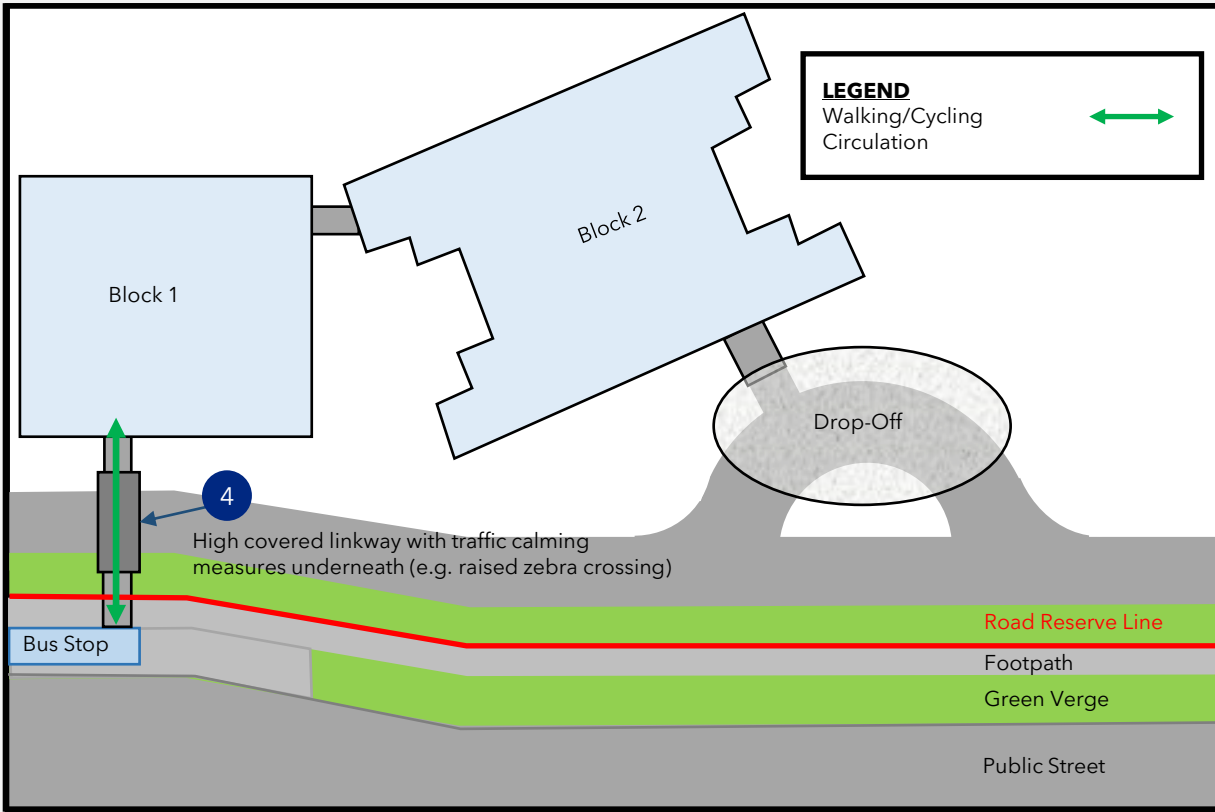

- 4** Provision of traffic calming measures at the crossing point

3.0 PEDESTRIAN ACCESS

It is important to ensure that sight visibility at pedestrian access is not hindered by hard structures and tall/dense vegetation to minimise any possible collisions. Splayed/porous design would allow users exiting the development to clearly see incoming pedestrians and active mobility device users commuting along the path and vice versa, ensuring that there is sufficient time to take any necessary evasive actions to avoid collisions. For the safety of development users, pedestrian access shall be positioned away from the vehicular access.

DESIGN CONSIDERATIONS

- Splayed/porous design (eg. visually permeable fencing) near pedestrian access
- Hard structures and tall/dense vegetation (more than 0.5m) should be avoided within the line of sight triangle
- To illustrate that minimum 12m/23m stopping sight distance can be achieved along the footpath/cycling path outside development
- Pedestrian refuge is highly encouraged to provide a safe holding area for development users
- Avoid the provision of turnstiles as they are not BFA/cyclist friendly
- Locate pedestrian access such that it provides users with direct access to transport nodes and bicycle parking

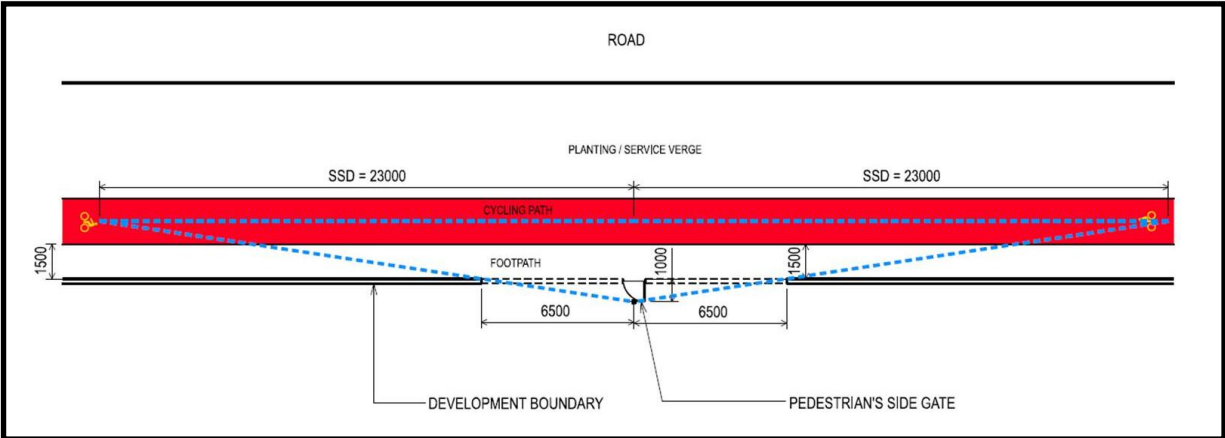

Figure 3.1 - Designing for Clear Line of Sight at Pedestrian Access (Cycling Path)

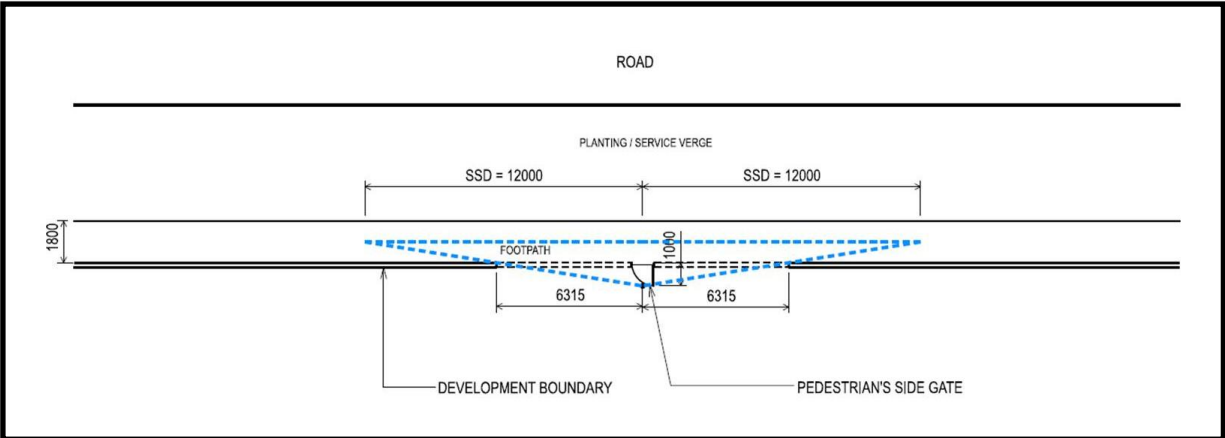

Figure 3.2 - Designing for Clear Line of Sight at Pedestrian Access (Footpath)

3.0 PEDESTRIAN ACCESS

DESIGN WITH CLEAR LINE OF SIGHT



Figure 3.4 - Pedestrian Access with Porous Wall and Minimal Vegetation

DESIGN WITH OBSTRUCTED LINE OF SIGHT (TO AVOID)



Figure 3.5 - Pedestrian Access with Non Porous Wall



Figure 3.6 - Pedestrian access with Tightly Spaced Louvres

3.1 Information to be Incorporated into DC Plans

- 1) The layout plan and elevation view shall be submitted for LTA's evaluation.
- 2) The submission of 3D artist impressions would help to better illustrate the design and facilitate clearance.

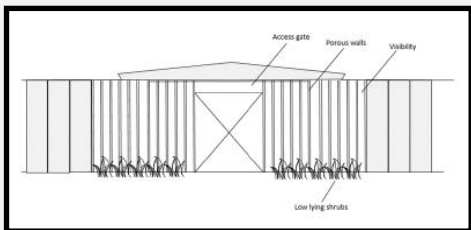

Figure 3.7 - Example of Elevation View



Figure 3.8 - Example of 3D Artist Impression

4.0 BICYCLE PARKING

Developments are required to comply with the bicycle parking provision as prescribed in the prevailing Code of Practice for Vehicle Parking Provision - Annex A.

The bicycle parking lots shall be easily accessible by public, located on the ground floor and near to the entrance of the development/lifts. The bicycle parking shall not be placed at corners of the development where it is difficult to access and locate, or in places with safety concerns (eg. next to vehicular down ramp).

If bicycle parking is situated at grade-separated level, access via lift is preferred. Please ensure lift is big enough to accommodate 2-3 horizontally standing bicycle and other passengers to avoid pedestrian and cyclist collision during peak hours. The recommended internal lift car size dimension is 2m x 2m.

For multi-block developments, sufficient bicycle parking spaces shall be provided at the individual blocks to serve the respective users where possible. It is recommended that the bicycle parking provision per block is proportional to its respective blocks' GFA.

Please refer to the bicycle parking layouts below for the minimum dimensions of parking spaces and circulation aisle.

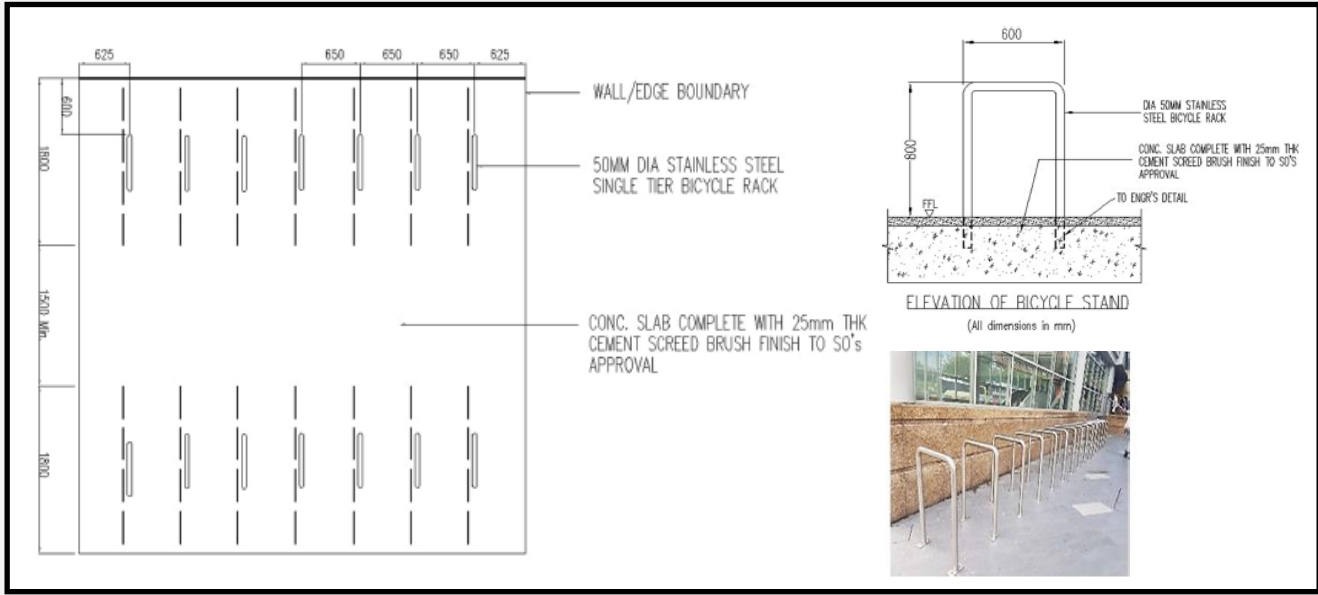

Figure 4.1 - Single Tier Bicycle Parking Details

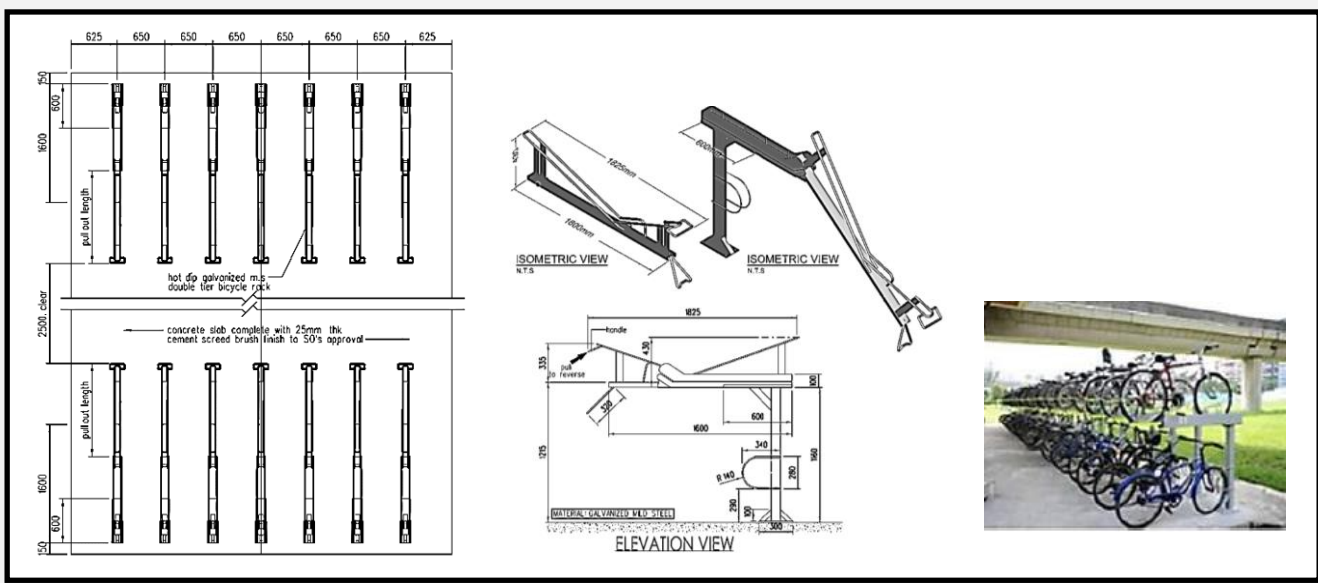

Figure 4.2 - Double Tier Bicycle Parking Details

4.0 BICYCLE PARKING

4.1 Information to be Incorporated into DC Plans

- 1) Provide a bicycle parking provision table indicating the total number of bicycle parking lots provided for long-term and short-term based on the type of use in development.
- 2) Number each bicycle parking rack in the drawings clearly.
- 3) Indicate the bicycle parking layout dimensions clearly (e.g. length of the parking lot, spacing between racks, circulation space, lateral clearance from hard structures).
- 4) Indicate the type of bicycle parking provided in the drawings (eg. single-tier or double-tier).
- 5) For alternative bicycle parking design, please provide additional 3D-illustrations, mock-up drawings, etc. to illustrate that there is sufficient clearance space to support successful bicycle rack operations, and that the design is user friendly and safe for cyclists (e.g. adequate space between bicycle racks to maximise parking capacity and prevent handlebars from clashing, adequate circulation space for users to lock/unlock their bicycles onto/from the racks and to push the bicycle in and out of the racks, adequate lateral clearance between bicycle rack and hard structures if any)

COMPUTATION FOR BIKE PARKING SPACE						
USAGE	TOTAL GFA	GFA BREAKDOWN	%	TOTAL	MIN BIKE LOTS	
					LONG TERM (80%)	SHORT TERM (20%)
OFFICE	57004.83	56530.54	100	92	74	18
RESTAURANT		474.29	0		-	-

Table 4.1 - Example of Bicycle Parking Provision Table

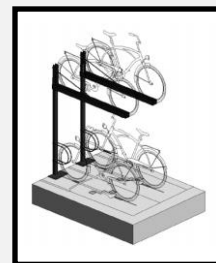

Figure 4.3 - Example of Isometric view of Bicycle Parking Rack

4.2 Geo-fencing Requirements for Bicycle Parking

24/7 publicly accessible bicycle parking lots on Statutory Board, State Land, and land subjected to landowner’s agreement would need to be affixed with QR codes and geo-fenced as part of LTA’s efforts to keep track of bicycle parking island wide. Please make a submission with the following details to LTA_AMU_Registry@lta.gov.sg, 2 months before completion of bicycle parking.

- 1) Type of bicycle parking implemented (racks or yellow box)
- 2) Number of bicycle lots/size of yellow box (in mm and number of bicycles that it can accommodate)
- 3) Photo and description of the exact location where racks/yellow box would be located
- 4) Geo-coordinates of racks/yellow box
 - Stand at location of racks/yellow box
 - Open Google Map app
 - Pin the location by holding the pin
 - Scroll down to find the geo-coordinates



Figure 4.4 - Example of Photo with Description

5.0 END-OF-TRIP FACILITIES

To improve the viability of cycling as a mode of transport, designers are encouraged to provide supporting End-of-Trip Facilities close to bicycle parking areas, especially for long-term bicycle parking. Developers/owners/building management committees may consider providing the following facilities within their development:

- Sheltered Bicycle Parking Spaces
- Shower Facilities, Lockers, Changing Room
- Bicycle Repair Stations, Air Pumps
- Security features such as CCTV

Please refer to the prevailing COP for Street Work Proposals relating to Development Works -Table 3.6 on the recommended provision and guidelines for End-of-Trip Facilities.

EOT facilities shall be easily accessible and near to bicycle parking lots for the convenience of cyclists.

All toilet and shower facilities shall meet the National Environment Agency (NEA)'s minimum requirements and comply with the Building & Construction Authority (BCA)'s Code on Accessibility in the Built Environment.

5.1 Information to be Incorporated into DC Plans (Applicable for Developments with WCP)

- 1) Include a End-of-Trip Facilities provision table on the site plan, indicate the total number of End-of-Trip Facilities (e.g. shower, locker) provided based on GFA, and different storey/cluster if any.
- 2) Label the type of End-of-Trip facilities provided (e.g. shower, locker) and number each facility clearly in the drawings.

S/N	STOREY	CLUSTER NO.	BICYCLE PARKING	END-OF-TRIP FACILITIES									
				SHOWERS		TOILETS		LOCKERS		PMD LOCKERS	OTHER FACILITIES	HCP WASHROOM	FAMILY ROOM
				MALE	FEMALE	MALE	FEMALE	MALE	FEMALE				
1	L3 BLOCK 1 (DU= 61)	L3-1	12	NO EOT FACILITIES REQUIRED FOR RESIDENTIAL BICYCLE PARKING PROVISIONS									
2	L3 BLOCK 2 (DU= 68)	L3-2	14										
3	L3 BLOCK 3 (DU= 80)	L3-3	16										
4	L3 BLOCK 4 (DU= 78)	L3-4	16										
5	L3 BLOCK 5 (DU= 76)	L3-5	16										
6	L3 BLOCK 6 (DU= 70)	L3-6	14										
7	L3 BLOCK 7 (DU= 54)	L3-7	12										
8	SHORT-TERM BICYCLE	L3-8	24										
9	L1 (LTA-BUS INTERCHANGE)	L1-1	150	0	0	0	0	0	0	0	0	0	0
10	BASEMENT 1	B1-1	566	6	6	1	1	48	52	17	2173 SQM	1	1
		B1-2	622	6	6	1	1	48	52	23	7347 SQM	1	1
TOTAL PROVISION			1,452	12	12	2	2	94	104	40	95.20 SQM	2	2

Table 5.1 - Example of Bicycle Parking and End-Of-Trip Facilities Provision Table Breakdown based on Cluster

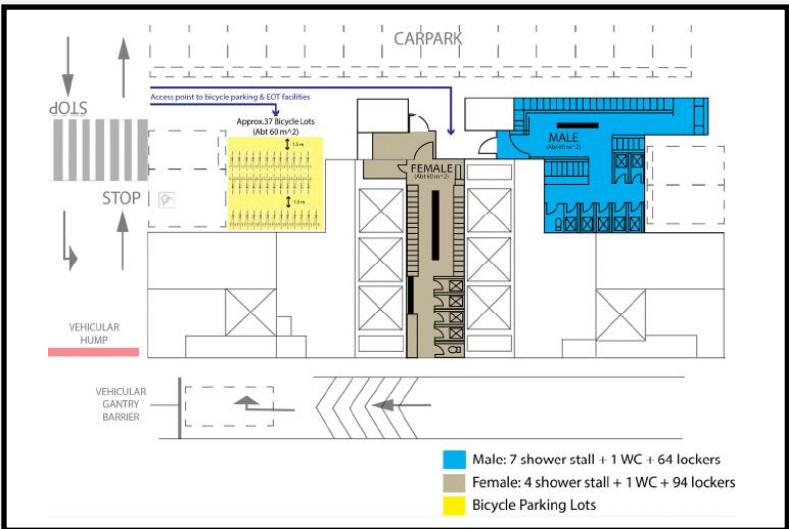

Figure 5.1 - Example of a Bicycle Parking and End-of-Trip Facilities Plan

6.0 INTERNAL CIRCULATION

Internal circulation routes from footpath/cycling path along public road to the lifts/lobbies, bicycle parking and End-Of-Trip (EOT) facilities shall be safe, direct and comfortable.

DESIGN CONSIDERATIONS

- Internal walking/cycling circulation routes shall be separated from vehicular driveway to avoid sharing of space with motorists for the safety of pedestrians/cyclists.
- Internal walking/cycling circulation routes shall not be located along carpark ramps or where cyclists are required to pass through carpark barriers.
- Internal walking/cycling circulation routes shall not cut through car parks and internal driveways to minimise conflict points with motorists as much as possible
- Internal walking/cycling circulation routes shall be free of encumbrances and with good sight visibility (e.g. no hard structures)
- Internal cyclist circulation routes shall be tapered smoothly for the safety of users (e.g. no sharp turns)
- Traffic calming measures and safe crossings are provided if the internal walking/cycling routes cut across vehicular circulation
- The entrance doors along internal circulation routes to bicycle parking shall be cyclist friendly (e.g. automatic door, step free access)
- If there are internal BFA ramps/slopes/paths with level difference, please assess the risk of cyclists from falling over. Please propose mitigating measures where appropriate.

6.1 Information to be Incorporated into DC Plans (Applicable for Developments with WCP)

- 1) Indicate proposed pedestrian, cyclist and vehicular accesses
- 2) Indicate the intended walking/cycling circulation route from development accesses to lifts/lobbies, bicycle parking and EOT facilities
- 3) If demarcated lanes, traffic calming measures and safe crossings are to be provided, please annotate clearly in drawings
- 4) If there are entrance doors along internal circulation routes to bicycle parking, please indicate the door type (e.g. automatic door)

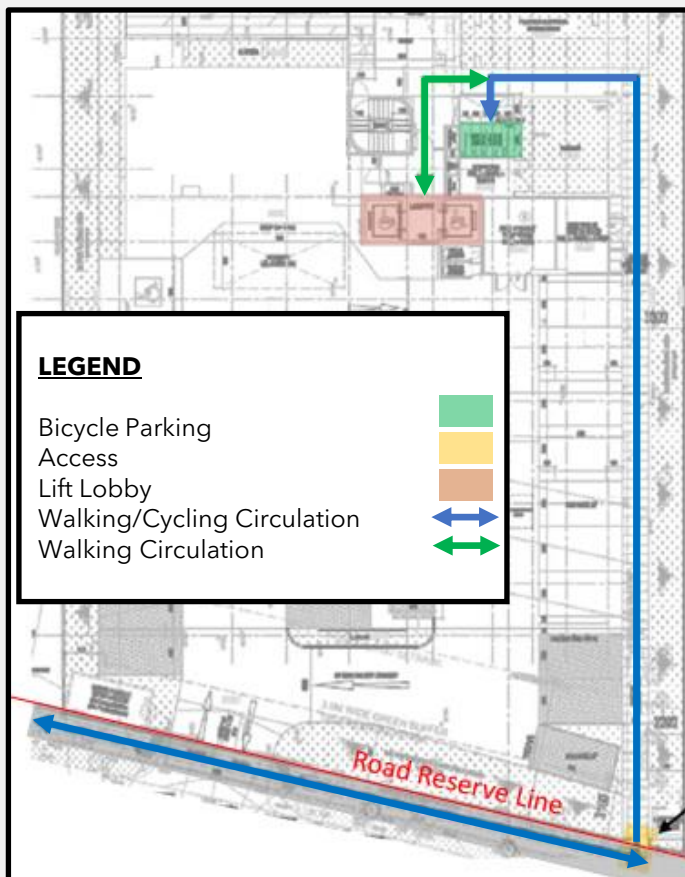

Figure 6.1 - Example of DC Plan indicating Walking/Cycling Circulation Route to Bicycle Parking

7.0 WAYFINDING SIGNAGE

Wayfinding is an integral part of a user's experience during their visit to developments for a safe, direct and comfortable walking or cycling experience. QPs/developers are strongly encouraged to provide directional signage with essential information for pedestrians and cyclists, such as directions to the nearest MRT stations and other key transport nodes. Wayfinding will also serve to guide cyclists to parking facilities and help to reduce indiscriminate parking around the development. The below are several points that QPs/developers may consider when designing wayfinding for the development:

DESIGN CONSIDERATIONS

- Proper design and placement principles are important to the design of a holistic wayfinding system that is not only clear and concise, but intuitive for first-time and even regular visitors.
- Provision of directional signage to bicycle parking/EOT facilities and nearby transportation nodes along main walking/cycling circulation corridors and at decision making zones.
- Provision of confirmation/repeater signage at locations where there are long stretches without signage (30-50m indoors, 50-100m outdoors)
- If there are bicycle parking/EOT facilities that are not located on ground level, provide directional signage along main walking/cycling circulation corridors to guide visitors to access lifts to bicycle parking/EOT facilities.
- Placement of signage shall not obstruct line of sight of pedestrians, motorists and cyclists, resulting in potential conflicts.
- Provide 0.5m lateral clearance between the signage and clear width of path to prevent the bicycle handlebar from hitting the signage and minimise any potential accidents.
- QP is recommended to use bicycle logo with letter P to indicate Bicycle Parking and LTA icons (and caplet) design for Public Transport icons.



Note: Refer to the prevailing [COP for Street Work Proposals relating to Development Works - Appendix 3D: Guide for Adequate Provision of Wayfinding Signage within Developments](#) for more detailed guidelines.

7.1 Information to be Incorporated into DC/BP Plans (Applicable for Developments with WCP)

- 1) Indicate the intended walking/cycling circulation corridors from development accesses leading to bicycle parking/EOT Facilities/lobbies/lifts/transport nodes
- 2) Indicate key decision making zones which include intersection of walking/cycling flows, vertical circulation zones (lift lobbies/escalators)
- 3) Show exact placement of wayfinding signage along main circulation corridors leading to bicycle parking/EOT Facilities/lobbies/lifts/transport nodes
- 4) Provide wayfinding signage design details (including dimensions, information to be indicated in the signage and rationale of wayfinding family signage). This may be submitted as a signage family for easy reference.
- 5) Indicate the type of wayfinding signage provided (e.g. identity, directional, informational and confirmation)

1 WALKING AND CYCLING DESIGN GUIDE

- Guide private developers, the building industry, consultants, and government agencies in the planning and designing active mobility infrastructure.
- Provide the considerations behind the standard design of the various infrastructure.
- Complement various agencies' technical requirements in active mobility related designs.

2 COP FOR STREET WORK PROPOSALS RELATING TO DEVELOPMENT WORKS

- Chapter 3 on Requirements for WCP Submission
- Appendix 3C - Guide for Pedestrian Accesses and Conflict Treatments
- Appendix 3D - Guide for Adequate Provision of Wayfinding Signage within Developments
- Appendix 3E - Guide for Bicycle Parking and Related Facilities

3 COP FOR VEHICLE PARKING PROVISION

- Requirements on bicycle parking provision, and minimum dimensions of parking spaces and circulation aisle.

4 STANDARD DETAILS OF ROAD ELEMENTS (SDRE)

- Chapter 21 - Cycling Path

5 DBC TECHNICAL WEBINAR - DESIGNING FOR ACTIVE MOBILITY

- [Slides](#)
- [Video](#)



ACTIVE MOBILITY CHECKLIST

For Layout Plan (Development Control Plan) Submission

(Not applicable to A&A proposals that do not involve proposed works within the public street, landed residential developments, individual shophouse developments along a street block)

Instructions:

1. This includes the list of Active Mobility items that would be reviewed by LTA when processing Development Control (DC) plans. To facilitate review and clearance, please incorporate the items below in the plans.
2. **For Developments without Walking and Cycling Plan (WCP), please complete sections 1 to 4. For Developments with WCP, please complete sections 1 to 7.**
3. (✓) Tick the appropriate box for all items. (**I** – Incorporated, **NI** – Not Incorporated, **NA** – Not applicable)
4. All “Incorporated” items are to be clearly reflected in the drawings.
5. The QP shall state the reasons for all “Not Incorporated” items in the ‘Remarks’ column.
6. Please refer to “Active Mobility Design Guide for Development Submissions” for better appreciation of the design considerations.

General	
(a) <i>(Applicable for Developments with WCP)</i> Indicate if provisions in DC plans and Walking and Cycling Plan (WCP) are consistent. If not aligned, highlight and indicate the list of deviations with clear descriptions.	(Consistent / Not Consistent) Remarks, if any
(b) Indicate if development has a boundary wall	(With / Without boundary wall)
(c) Indicate expected development TOP date	(mm/yyyy)
(d) Please submit 3D model, if available.	(Submitted – Available / Not Submitted – Not Available)

	I	NI	NA	Remarks																		
1 Walking and Cycling Infrastructure																						
<i>(Public Path including 24/7 Publicly Accessible Throughblock Links)</i>																						
1.1 Indicate type of paths provided in the ‘Remarks’ column. Indicate width of the paths provided clearly in DC plans.	<input type="checkbox"/>	<input type="checkbox"/>	<input type="checkbox"/>																			
<table border="1" style="width: 100%; border-collapse: collapse; margin-bottom: 10px;"> <thead> <tr style="background-color: black; color: white;"> <th style="width: 10%;">Type</th> <th style="width: 40%;">Path</th> <th style="width: 50%;">Standard Width (m)</th> </tr> </thead> <tbody> <tr> <td style="text-align: center;">1</td> <td style="text-align: center;">Footpath</td> <td style="text-align: center;">- 1.8m (standalone) - 1.5m (next to cycling path)</td> </tr> <tr> <td style="text-align: center;">2</td> <td style="text-align: center;">Covered Linkway</td> <td style="text-align: center;">- 2.4m (by default) - 3.6m (with high pedestrian traffic)</td> </tr> <tr> <td style="text-align: center;">3</td> <td style="text-align: center;">Cycling Path</td> <td style="text-align: center;">- 2.0m (intra-town) - 2.5m (inter-town)</td> </tr> <tr> <td style="text-align: center;">4</td> <td style="text-align: center;">Footpath & Cycling Path</td> <td style="text-align: center;">3.5m (1.5m for footpath, 2m for cycling path)</td> </tr> <tr> <td style="text-align: center;">5</td> <td style="text-align: center;">Covered Linkway & Cycling Path</td> <td style="text-align: center;">4.4m (2.4m for covered linkway, 2m for cycling path)</td> </tr> </tbody> </table> Indicate gradient of cycling path (if any) clearly in DC plans. The recommended gradient is gentler or equal to 1:25 or not steeper than existing road gradient.	Type	Path	Standard Width (m)	1	Footpath	- 1.8m (standalone) - 1.5m (next to cycling path)	2	Covered Linkway	- 2.4m (by default) - 3.6m (with high pedestrian traffic)	3	Cycling Path	- 2.0m (intra-town) - 2.5m (inter-town)	4	Footpath & Cycling Path	3.5m (1.5m for footpath, 2m for cycling path)	5	Covered Linkway & Cycling Path	4.4m (2.4m for covered linkway, 2m for cycling path)				
Type	Path	Standard Width (m)																				
1	Footpath	- 1.8m (standalone) - 1.5m (next to cycling path)																				
2	Covered Linkway	- 2.4m (by default) - 3.6m (with high pedestrian traffic)																				
3	Cycling Path	- 2.0m (intra-town) - 2.5m (inter-town)																				
4	Footpath & Cycling Path	3.5m (1.5m for footpath, 2m for cycling path)																				
5	Covered Linkway & Cycling Path	4.4m (2.4m for covered linkway, 2m for cycling path)																				

ACTIVE MOBILITY CHECKLIST

For Layout Plan (Development Control Plan) Submission

(Not applicable to A&A proposals that do not involve proposed works within the public street, landed residential developments, individual shophouse developments along a street block)

		I	NI	NA	Remarks												
1.2	There shall be no encumbrances along the path (e.g. linkway columns, signage, OG Boxes, lamp poles). If there are any structures along the path, indicate clear width of the paths.	<input type="checkbox"/>	<input type="checkbox"/>	<input type="checkbox"/>													
1.3	<p>There shall be no sharp turns (e.g. 90 degree kinks due to POB columns) along the path. Please illustrate and ensure smooth tapering based on the minimum turning radius and stopping sight distance indicated in the table.</p> <p>There shall be no obstructions to line of sight along the path.</p> <table border="1" style="margin-left: auto; margin-right: auto;"> <thead> <tr> <th style="text-align: center;">Type of Path</th> <th style="text-align: center;">Design Speed (km/h)</th> <th style="text-align: center;">Minimum Radius (m)</th> <th style="text-align: center;">Stopping Sight Distance</th> </tr> </thead> <tbody> <tr> <td style="text-align: center;">Footpath</td> <td style="text-align: center;">15</td> <td style="text-align: center;">6.5</td> <td style="text-align: center;">12</td> </tr> <tr> <td style="text-align: center;">Cycling Path</td> <td style="text-align: center;">25</td> <td style="text-align: center;">18</td> <td style="text-align: center;">23</td> </tr> </tbody> </table>	Type of Path	Design Speed (km/h)	Minimum Radius (m)	Stopping Sight Distance	Footpath	15	6.5	12	Cycling Path	25	18	23	<input type="checkbox"/>	<input type="checkbox"/>	<input type="checkbox"/>	
Type of Path	Design Speed (km/h)	Minimum Radius (m)	Stopping Sight Distance														
Footpath	15	6.5	12														
Cycling Path	25	18	23														
1.4	If there is level difference to be mitigated within the development and path within road reserve, please indicate and provide BFA ramp of gradient that is gentler or equal to 1:12.	<input type="checkbox"/>	<input type="checkbox"/>	<input type="checkbox"/>													
1.5	All paths shall be routed behind the taxi stand / bus stop / pick-up-drop off / MRT entrance (if any) with space provided in accordance with the prevailing SDRE.	<input type="checkbox"/>	<input type="checkbox"/>	<input type="checkbox"/>													
1.6	<p>Indicate stopping sight distance at corners, and highlight obstructions to line of sight, if any. You may refer to “Section 1 of Active Mobility Design Guide for Development Submissions” for further guidance.</p> <p>To enhance safety, splayed/porous design for boundary wall at corners is recommended.</p> <p>For splayed design, avoid placement of any hard structures and tall/dense vegetation (more than 0.5m) within the visibility splay area to prevent any obstruction to line of sight.</p>	<input type="checkbox"/>	<input type="checkbox"/>	<input type="checkbox"/>													
1.7	<p><i>(Applicable for Developments with Cycling Path)</i></p> <p>To enhance safety, railings with minimum 1.2m height are recommended along cycling path that has lateral clearance of less than 1.5m from the edge and</p> <p style="margin-left: 40px;">(1) Level difference of 1m or more and (2) Equal or steeper than 1:3.</p> <p>Provision of railings shall not reduce clear width of the cycling path.</p>	<input type="checkbox"/>	<input type="checkbox"/>	<input type="checkbox"/>													
1.8.1	<p><i>(Applicable for Developments with Cycling Path)</i></p> <p>For cycling path at a signalised junction, widen pedestrian crossing to minimum 5m in accordance with the prevailing SDRE (SDRE17/21/CYC1). Indicate width of the crossings clearly on DC plans.</p>	<input type="checkbox"/>	<input type="checkbox"/>	<input type="checkbox"/>													
1.8.2	For cycling path at a signalised mid-block, widen mid-block crossing to provide bicycle crossing in accordance with the prevailing SDRE	<input type="checkbox"/>	<input type="checkbox"/>	<input type="checkbox"/>													

ACTIVE MOBILITY CHECKLIST

For Layout Plan (Development Control Plan) Submission

(Not applicable to A&A proposals that do not involve proposed works within the public street, landed residential developments, individual shophouse developments along a street block)

		I	NI	NA	Remarks
	(SDRE17/21/CYC5). Indicate width of the crossings clearly in DC plans.				
1.8.3	For cycling path at an unsignalized road, provide 4m wide raised zebra crossing in accordance with the prevailing SDRE (SDRE17/21/CYC2). Indicate width of the crossings clearly in DC plans.	<input type="checkbox"/>	<input type="checkbox"/>	<input type="checkbox"/>	
2 Vehicular Access					
2.1	<p>Indicate stopping sight distance at vehicular access, and highlight obstructions to line of sight, if any. You may refer to “Section 2 of Active Mobility Design Guide for Development Submissions” for further guidance.</p> <p>To enhance safety, splayed/porous design for boundary wall near vehicular accesses is recommended.</p> <p>For splayed design, avoid placement of any hard structures including signages, guard house and tall/dense vegetation (more than 0.5m) within the visibility splay area to prevent any obstruction to line of sight.</p>	<input type="checkbox"/>	<input type="checkbox"/>	<input type="checkbox"/>	
2.2	To further enhance safety at vehicular accesses, safety features (e.g. traffic calming measures, signages) are recommended to slow down motorists.	<input type="checkbox"/>	<input type="checkbox"/>	<input type="checkbox"/>	
3 Pedestrian Access					
3.1	To enhance safety, separate pedestrian access (not sharing with vehicular access) is recommended.	<input type="checkbox"/>	<input type="checkbox"/>	<input type="checkbox"/>	
3.2	<p>Indicate stopping sight distance at pedestrian access, and highlight obstructions to line of sight, if any. You may refer to “Section 3 of Active Mobility Design Guide for Development Submissions” for further guidance.</p> <p>To enhance safety, splayed/porous design for boundary wall near pedestrian accesses is recommended.</p> <p>For splayed design, avoid placement of any hard structures including signages, guard house and tall/dense vegetation (more than 0.5m) within the visibility splay area to prevent any obstruction to line of sight.</p>	<input type="checkbox"/>	<input type="checkbox"/>	<input type="checkbox"/>	
3.3	To further enhance safety at pedestrian accesses, safety features (e.g. pedestrian refuge, signages) are recommended.	<input type="checkbox"/>	<input type="checkbox"/>	<input type="checkbox"/>	
4 Bicycle Parking					
4.1	<p>Number each bicycle parking clearly in DC plans.</p> <p>Bicycle parking lots shall be provided in accordance with prevailing parking requirements in the prevailing “COP for Vehicle Parking Provisions in Development Proposals”.</p>	<input type="checkbox"/>	<input type="checkbox"/>	<input type="checkbox"/>	
4.2	<p>Indicate dimensions of bicycle parking layout clearly in DC plans.</p> <p>For u bar and double tiered racks, bicycle parking layout shall comply with minimum geometry dimensions (e.g. spacing of the rack, circulation space, length of the parking lot, longitudinal clearance,</p>	<input type="checkbox"/>	<input type="checkbox"/>	<input type="checkbox"/>	

ACTIVE MOBILITY CHECKLIST

For Layout Plan (Development Control Plan) Submission

(Not applicable to A&A proposals that do not involve proposed works within the public street, landed residential developments, individual shophouse developments along a street block)

		I	NI	NA	Remarks
	lateral clearance) as stipulated in “Section 4 of Active Mobility Design Guide for Development Submissions”.				
4.3	As a good practice, bicycle parking area is recommended to be easily accessible by public, located on ground floor and near to the entrances of development. If the bicycle parking area is not located on ground floor, access via lift (2m x 2m) is recommended.	<input type="checkbox"/>	<input type="checkbox"/>	<input type="checkbox"/>	
5	End-of-Trip Facilities <i>(Applicable for Developments with WCP)</i>				
5.1	Indicate type of EOT facilities provided and number each facility clearly in DC plans.	<input type="checkbox"/>	<input type="checkbox"/>	<input type="checkbox"/>	
5.2	For design excellence, EOT facilities area is recommended to be easily accessible and located near to bicycle parking lots.	<input type="checkbox"/>	<input type="checkbox"/>	<input type="checkbox"/>	
6	Internal Circulation <i>(Applicable for Developments with WCP)</i>				
6.1	To enhance safety of the development, internal walking and cycling circulation routes are recommended to be separated from vehicular driveway.	<input type="checkbox"/>	<input type="checkbox"/>	<input type="checkbox"/>	
6.2	Highlight and indicate conflict points, if any. To enhance safety of the development, conflict mitigating measures (e.g. humps, crossings) are recommended.	<input type="checkbox"/>	<input type="checkbox"/>	<input type="checkbox"/>	
7	Wayfinding Signage <i>(Applicable for Developments with WCP)</i>				
7.1	Indicate intended walking/cycling circulation corridors from development accesses leading to bicycle parking/EOT facilities/lobbies/lifts/transport nodes.	<input type="checkbox"/>	<input type="checkbox"/>	<input type="checkbox"/>	
7.2	Indicate decision-making zones, including intersection of walking/cycling flows, vertical circulation zones (e.g. lifts, escalators).	<input type="checkbox"/>	<input type="checkbox"/>	<input type="checkbox"/>	
7.3	Provide adequate signages to guide users along intended walking/cycling circulation corridors and key decision-making zones to bicycle parking/EOT facilities/lobbies/lifts/transport nodes and vice versa.	<input type="checkbox"/>	<input type="checkbox"/>	<input type="checkbox"/>	
7.4	To enhance safety of the development, careful placement of signages is recommended to prevent any obstruction to line of sight.	<input type="checkbox"/>	<input type="checkbox"/>	<input type="checkbox"/>	

For Qualified Person’s Endorsement

Name of Qualified Person:

Signature and Date: